

# TECHNICAL GUIDE AND PARTS LIST

CAL. V250A  
V251A

## ANALOGUE QUARTZ





### CONTENTS

I. SPECIFICATIONS .....	1
II. LIST OF SCREWS USED.....	1
III. DISASSEMBLING, REASSEMBLING AND LUBRICATING .....	2 ~ 4
IV. CHECKING AND ADJUSTMENT .....	5
1. Structure of circuit block.....	5
2. Procedure for checking and adjustment.....	5 ~ 7
V. PARTS LIST.....	8

## I. SPECIFICATIONS

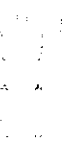
Item		Cal. No.	V250A	V251A
Indication system			Two hands (hand moves at 20 sec. intervals)	Three hands
Driving system			Step motor	
Additional mechanism			—	Electronic reset switch Second setting device
Loss/gain			Monthly rate: less than 20 seconds at normal temperature range	
Movement size	Size of main plate		φ18.4 mm (6H - 12H), 15.3 mm (3H - 9H)	
	Casing diameter		17.8 mm	
	Height		2.4 mm	
Regulation system			—	
Quartz Tester measuring gate			Use for 10-second gate	
Battery			SEIKO (SEIZAIKEN) TR621SW, Maxell SR621SW, SONY EVEREADY 364 Voltage: 1.55V	
Battery life			Approx: 3 years	Approx: 2 years for SEIKO TR621SW 1.5 years for Maxell SR621SW and SONY EVEREADY 364
Jewels			0 jewel	

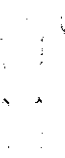
## II. LIST OF SCREWS USED

Shape	Part No.	Name	Shape	Part No.	Name
	012 057	Circuit block screw (1 pce.)		*012 060	Battery clamp screw (1 pce.)
	012 058	Train wheel bridge screw (2 pcs.)		012 708	Screw for battery connection (+) (2 pcs.)

\* The battery clamp screw is not used in some models.





## III. DISASSEMBLING, REASSEMBLING AND LUBRICATING

This section III only describes procedures for Cal. V251A.

Disassembling procedures: Figs ① ~ ④

Reassembling procedures: Figs ⑤ ~ ①

Lubricating:

Types of oil	Oil quantity
Moebius A 	Standard 
Seiko watch oil S-6 	Small 

- How to remove the winding stem

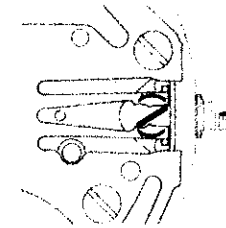

Insert a little bit large (-) screwdriver and turn it to right and left (in the direction of the arrow shown in the above figure) to remove the winding stem.

- ② Dial

The dial is fixed with its 2 legs inserted into the dial leg holes in the Dial spacer ②.

\* To remove the dial, insert a (-) screwdriver into the notch for dial removal and pry out the dial.

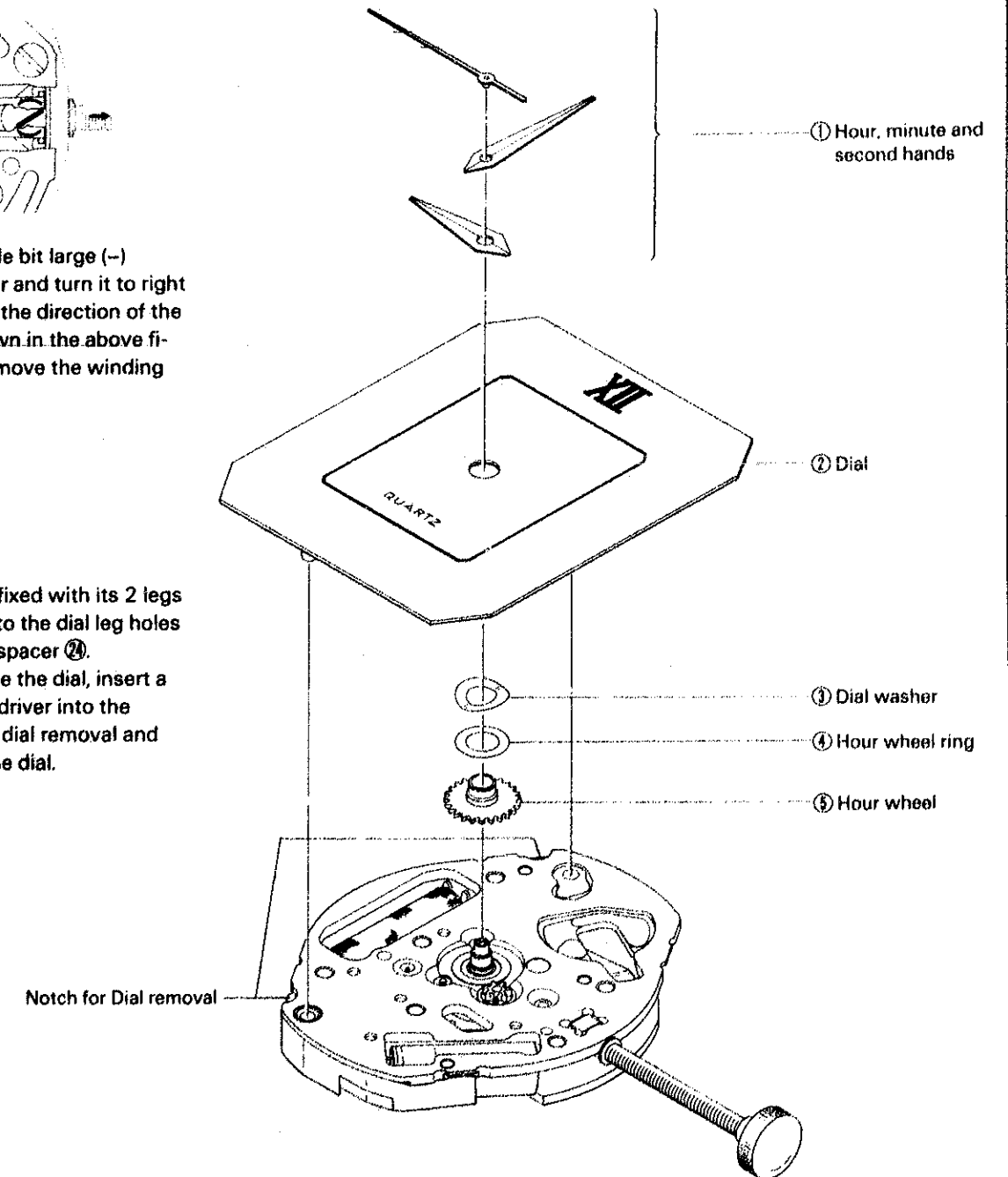

● Battery clamp screw ~ Train wheel bridge

\* In some models, a battery clamp and battery clamp screw are used.

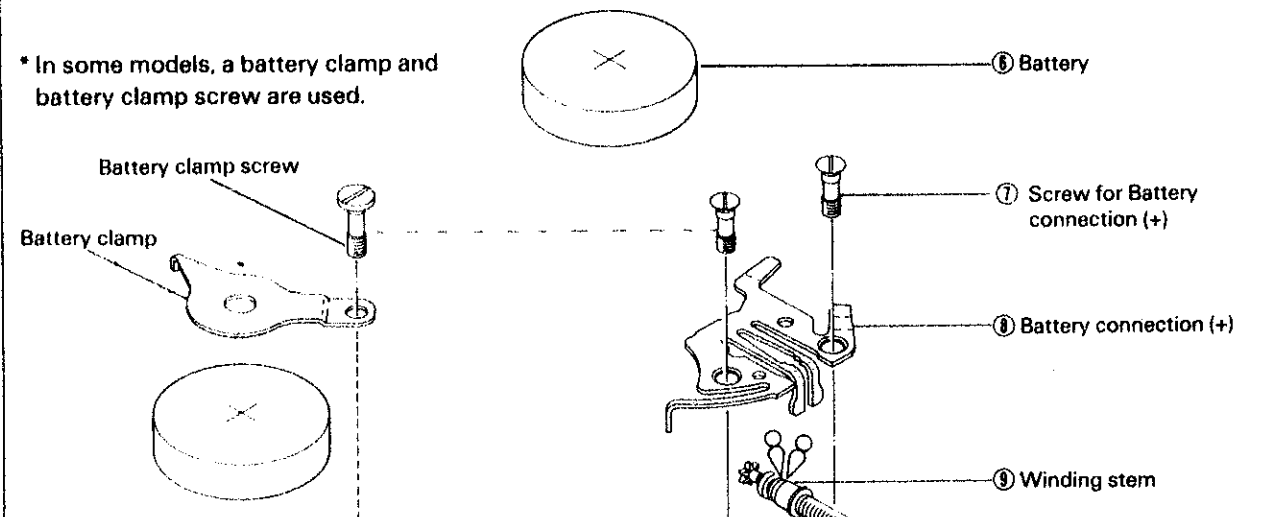

● Setting of the Train wheel setting lever ⑩

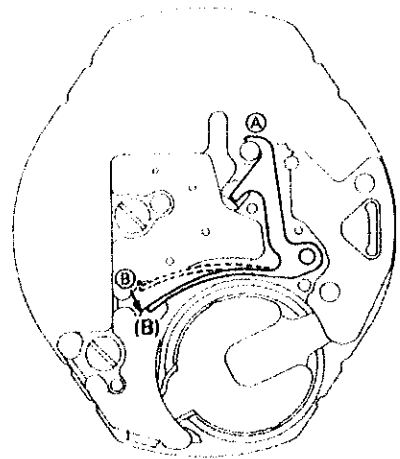

Assemble the train wheel setting lever ⑩ to the position indicated by solid line in the figure above. Set portion A first, then pull the portion B indicated by dotted line to the slot (B) and insert B into the slot (B) in the train wheel bridge ⑫ while keep pressing the portion A with a finger. When setting part A, take care not to override on to the fourth wheel and pinion ⑬.

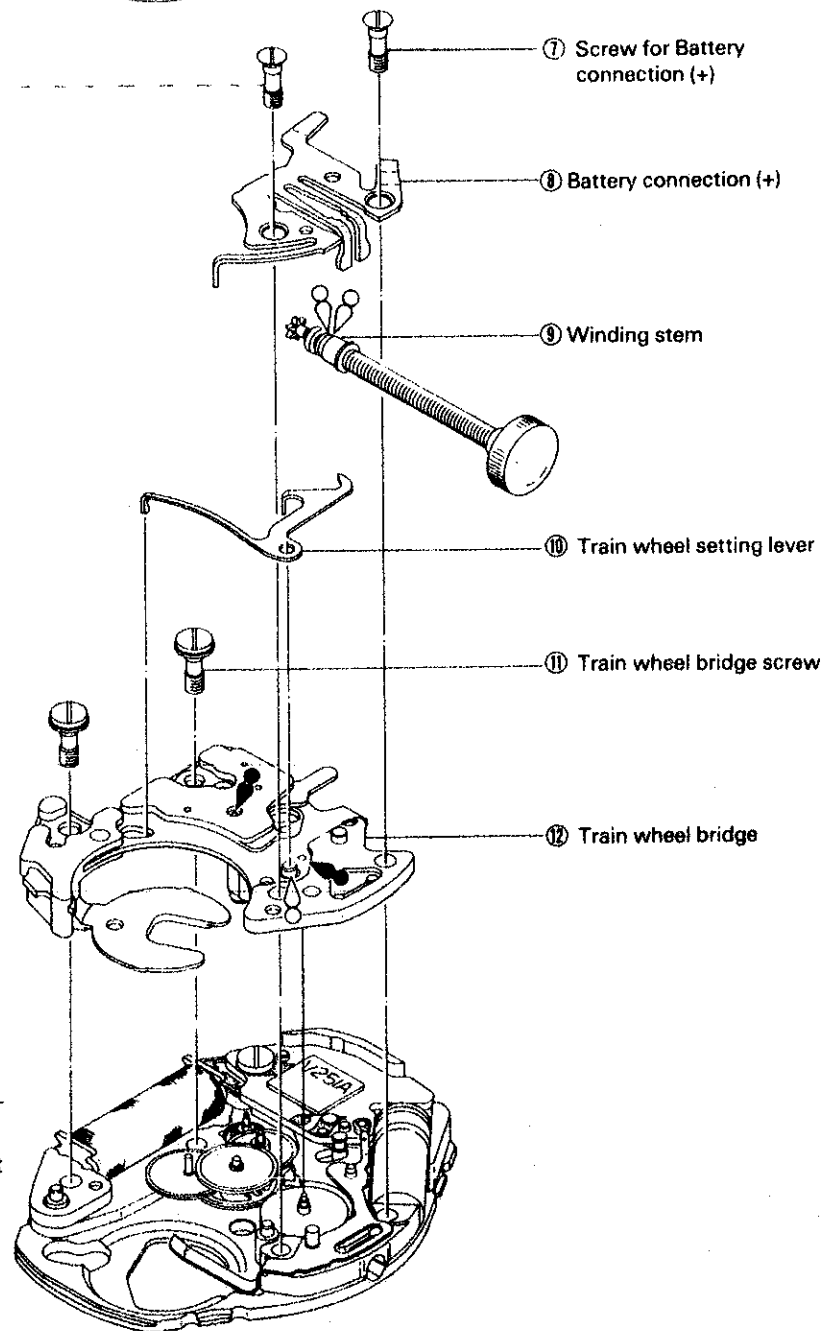

● Fourth wheel and pinion ~ Main plate

● Position of gear train

Cal. V250

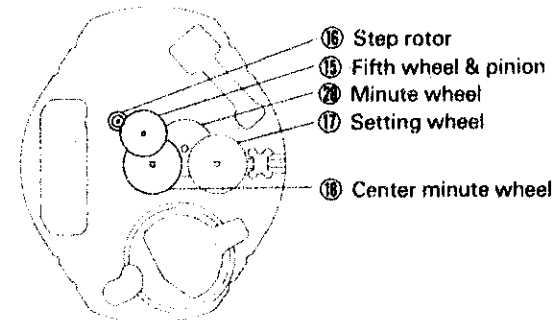

Cal. V251

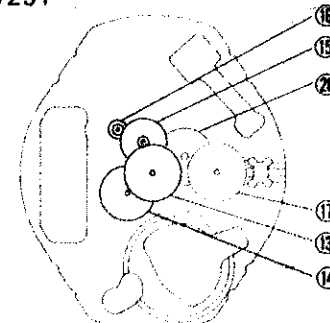

Note: As the step rotor ⑮ and fifth wheel and pinion ⑮ are made of plastic, take care not to damage the wheel, pinion and shaft.

● Position of reset lever ⑳

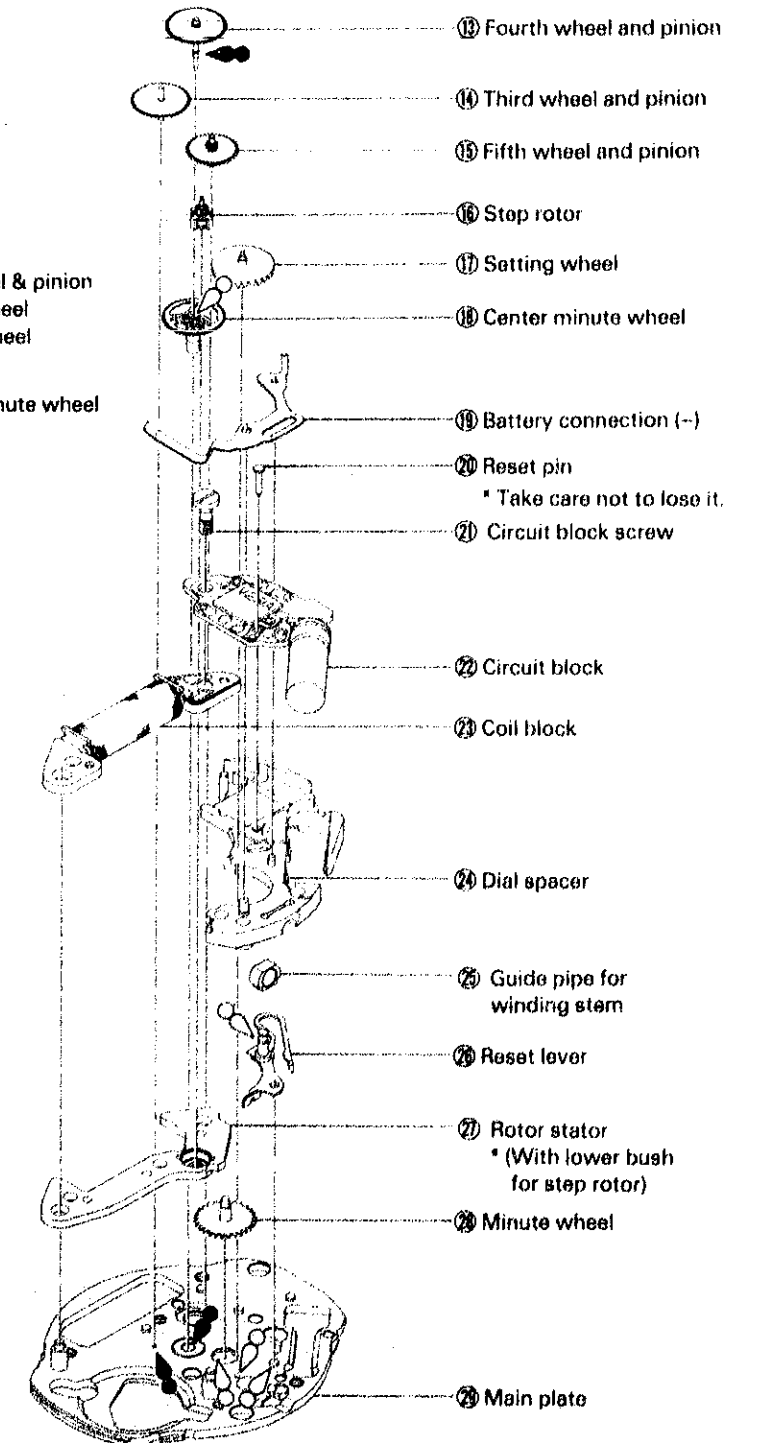
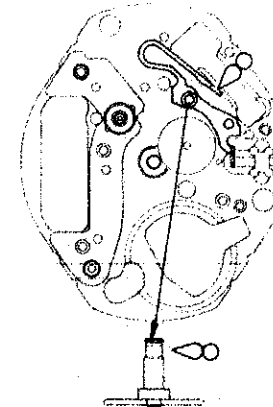

## IV. CHECKING AND ADJUSTMENT

### 1. Structure of circuit block

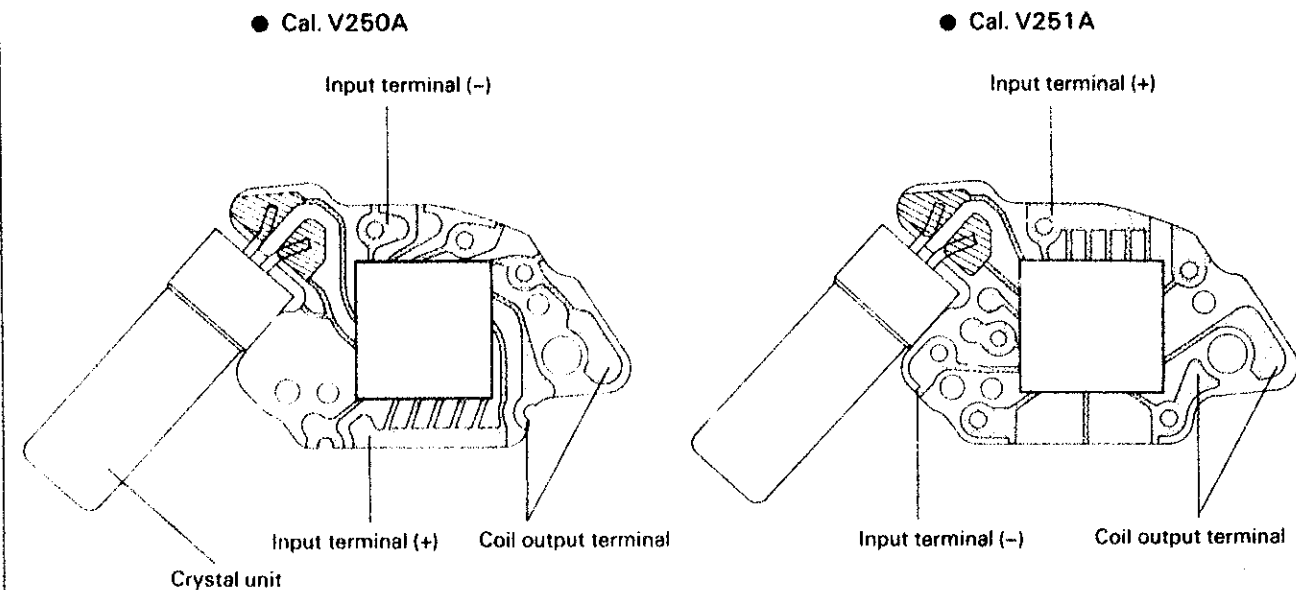

### 2. Procedure for checking and adjustment

- This section only gives the checking and adjustment procedure which is exclusive for this watch. For the normal checking and adjustment, refer to the "TECHNICAL GUIDE GENERAL INSTRUCTION, Analogue Quartz".
- The page numbers in the item correspond to those in the "TECHNICAL GUIDE GENERAL INSTRUCTION, Analogue Quartz".

#### OUTPUT SIGNAL p.6

1. Use the Quartz Tester.
2. Turn the measuring gate selection to "10-second" gate.

**NOTE:**  
Checking should be made with the crown set to normal position.

**Result:**  
Output signal: Normal  
No output signal: Defective

#### BATTERY VOLTAGE

Use the SEIKO Digital Multi Tester S-840A  
Range to be used: DC V

**NOTE:**  
Before measuring, short circuit the probes and confirm that the tester reads AUTO 00.0 mV or AUTO 00.1 mV.

**Result:**  
1.57V or more: Normal  
Less than 1.57V: Defective  
Replace the battery.

#### BATTERY CONDUCTIVITY p.9

Check the conductivity between battery and battery connection (-), etc.

#### CIRCUIT BLOCK CONDUCTIVITY p.9

Check the output terminal and pattern section contamination in the circuit block and check if the circuit is broken or short.

### COIL BLOCK

Check the coil block for broken wire and short circuit using the SEIKO Digital Multi Tester S-840A.  
Range to be used:  $\Omega$

#### NOTE:

- Before measuring, short circuit the probes and check to see if the tester sounds and reads from AUTO 00.2 $\Omega$  to AUTO 00.4 $\Omega$ . The actual resistance can be obtained by subtracting the initial value (00.2 - 00.4) from the measured value.
- When measuring, take care not to break the coil block leads.

#### Result:

- Cal. V250A  
1.7 ~ 2.1 k $\Omega$ : Normal  
Less than 1.7 k $\Omega$  (short circuit): Defective  
More than 2.1 k $\Omega$  (broken wire): Defective
- Cal. V251A  
2.3 ~ 2.7 k $\Omega$ : Normal  
Less than 2.3 k $\Omega$  (short circuit): Defective  
More than 2.7 k $\Omega$  (broken wire): Defective

### FRONT GEAR TRAIN MECHANISM P.11

Check the front gear train mechanism for play of step rotor and wheels and pinions, mis-installation, dust, lint, foreign matter, lubrication, etc.

### RESET CONDITION (only for Cal. V251A)

Check that the reset condition is correct.

1. Check through the access window at the center of the train wheel bridge.
  - (1) Crown at normal position

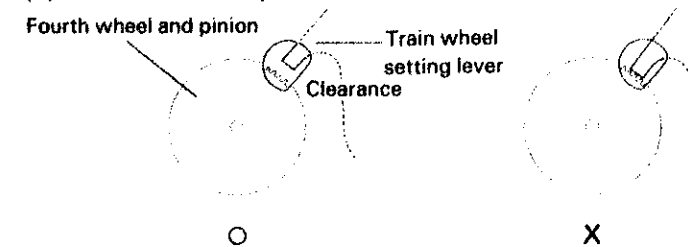

- (2) Crown at first click position



2. Check the output signal with the battery installed.

- (1) Crown at normal position

- (2) Crown at first click position

#### Result:

There is clearance: Normal  
No clearance: Defective  
Replace the train wheel setting lever or check the position of reset lever and train wheel setting lever.

#### Result:

No clearance: Normal  
There is clearance: Defective  
Replace the train wheel setting lever or check the position of reset lever and train wheel setting lever.

#### Result:

Output signal: Normal  
No output signal: Defective

#### Result:

No output signal: Normal  
Output signal: Defective

If there is an output signal in steps (1) and (2) or if there is an output signal in step (2) and no output in step (1), replace the reset lever.

### ACCURACY P.13

Check accuracy using Quartz Tester and an electromagnetic microphone (DM-1).

Measuring gate Cal. V250A — 10-second gate  
Cal. V251A — 10-second gate

**NOTE:**

Check accuracy with the crown at normal position.

**Result:**  
Monthly rate (at normal temperature range)  
Less than 20 seconds: Normal  
More than 20 seconds: Defective  
When the accuracy is largely defective, replace the circuit block.

### CURRENT CONSUMPTION

Use the SEIKO Digital Multi-Tester S-840A (with Multi Adaptor MA-40)  
Mode to be used:  $\mu A$

Red probe: Battery connection (+)  
Black probe: Battery connection (-)

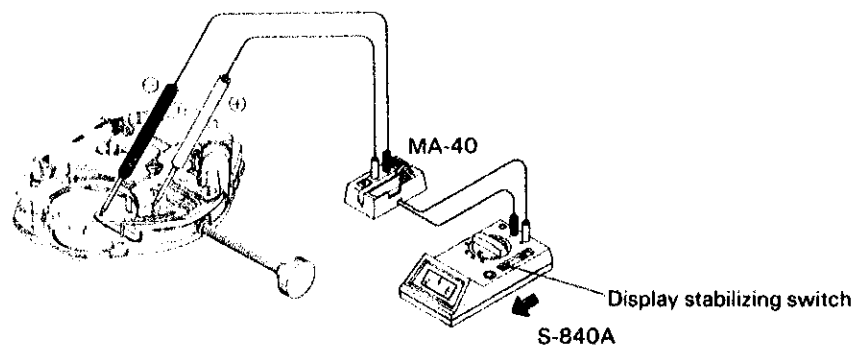

**Notes on the current consumption measurement (only for Cal. V250A)**

- (1) Set the display stabilizing switch to B position (in the direction of the arrow shown in the above figure).
- (2) Apply the red (+) and black (-) probes of the tester to battery connection (+) and battery connection (-) as shown in the above figure. The tester displays a value, indicating that electric current is flowing in the IC.
- (3) In addition to above, the measured value increases once every 20 seconds, since the step motor drive pulse is supplied to move the hand.
- (4) After approximately 60 seconds, the maximum figure at this time (hand moves every 20 seconds) indicates the average current consumption.

**Result:**  
● Cal. V250A  
Less than  $0.7 \mu A$ : Normal  
More than  $0.7 \mu A$ : Defective  
● Cal. V251A  
Less than  $1.3 \mu A$ : Normal  
More than  $1.3 \mu A$ : Defective  
\* When measuring, cover the MOS-IC with a black sheet.

### V. PARTS LIST

Cal. V250 A	
PARTS NO.	PARTS NAME
* 125 016	Train wheel bridge
238 233	Guide pipe for winding stem
261 237	Minute wheel
• 270 247	Center minute wheel
• 270 248	Center minute wheel
• 271 283	Hour wheel
• 271 284	Hour wheel
281 237	Setting wheel
• 351 131	Winding stem ( $\phi 80$ )
• 351 132	Winding stem ( $\phi 90$ )
491 122	Dial washer
493 130	Hour wheel ring (thickness 0.03 mm)
493 131	Hour wheel ring (thickness 0.05 mm)
493 132	Hour wheel ring (thickness 0.07 mm)
701 238	Fifth wheel and pinion
4000 065	Circuit block
4002 238	Coil block
4146 239	Step rotor
4225 237	Battery clamp
4239 025	Rotor stator with lower bush for step rotor
4270 237	Battery connection (-)
4271 243	Battery connection (+)
4408 240	Dial spacer
012 057	Circuit block screw
012 058	Train wheel bridge screw
012 060	Battery clamp screw
012 708	Screw for battery connection (+)
017 591	Reset pin
017 785	Lower bush for step rotor
• SEIKO (SEIZAIKEN) TR621SW	Battery
• MAXELL SR621SW	
• SONY EVEREADY 364	

**Remarks:**

\* Fourth wheel & pinion, Center minute wheel, Hour wheel

There are two different types as specified below.

Combination:

Cal. No.	*Type	Fourth wheel & pinion	Center minute wheel	Hour wheel
V250	M	—	270 247	271 283
	L	—	270 248	271 284

\*Abbreviation M.....Standard type  
(Movement size) L.....Long type

\* Winding stem

The type of winding stem is determined based on the design of case.

\*Train Wheel Bridge for Pulsar Watches \*125017 (Pulsar marking) -V250A-